

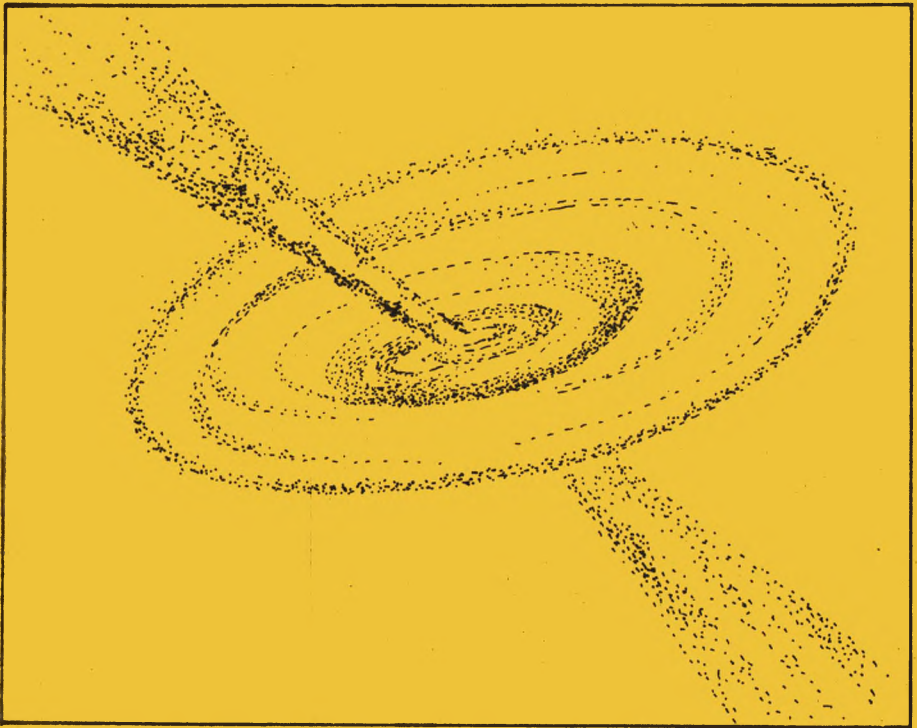

NOVA NOTES



BI-MONTHLY JOURNAL OF THE HALIFAX CENTRE

JUL -AUG 1983 VOL.14 , No 4

1983 HALIFAX CENTRE EXECUTIVE

- Honorary President - Dr. William Holden,
M.D., F.A.C.S.
- President - Kathy Oakley,
3140 Hemlock Avenue,
HALIFAX, N.S. B3L 4B6
- Vice President - David Tindall,
3231 Glendale Road,
HALIFAX, N.S. B3L 3S4
- Secretary - Wilf Morley,
34 Elizabeth Street,
BRIDGEWATER, N.S. B4V 1M2
- Treasurer - Randall Brooks,
71 Woodlawn Road,
DARTMOUTH, N.S. B2W 2S2
- Editor (NOVA NOTES) - Peter Steffin,
8 Auburn Drive,
DARTMOUTH, N.S. B2W 3S6
- National Rep. - Cathy McLeod,
2-6067 Fraser Street,
HALIFAX, N.S. B3H 1R8
- Librarian(s) - L. Burgoyne & J.S. Wells,
Saint Marys University,
HALIFAX, N.S. B3H 3C3
- Observing Chairman - Craig MacDonald,
12 Wheatstone Heights,
DARTMOUTH, N.S. B2Y 4C6
- Mailing Address - HALIFAX CENTRE, R.A.S.C.
c/o 1747 Summer Street,
HALIFAX, N.S. B3H 3A6
-

NOTICES

There will not be a regular meeting of the Halifax Centre of the R.A.S.C. for the month of July. There will however be an observing session on 19 July to be held at Shubie Park (weather permitting).

The dates for the camping/observing weekend have now been finalized and have been set for the weekend of 12th. to 14th. of August. The location is Dr. Holden's property as indicated on the map. Plan to attend and watch the Perseid meteor shower with a friend.

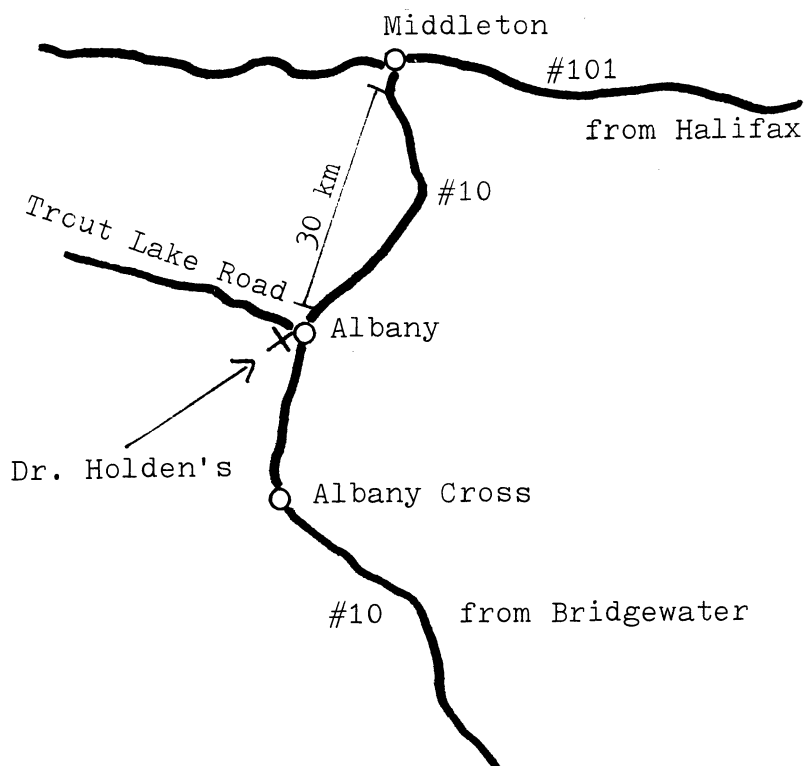

NOTICE OF MEETING

Date: Friday, 16 September, 8:00 PM

Place: Nova Scotia Museum: Meeting to be held in lower auditorium/theatre. Access from parking lot and side entrance.

Speaker & Topic: This meeting will feature Hugh Millward who will be talking about the L5 Society.

REFRESHMENTS WILL FOLLOW!

NOTICE OF MEETING

Date: Friday, 21 October, 8:00 PM

Place: Nova Scotia Museum: Meeting to be held in lower auditorium/theatre. Access from parking lot and side entrance.

Speaker & Topic: For this meeting we expect to show Dr. Holden's expedition film. Plan to attend as his films have always been of the greatest interest.

REFRESHMENTS WILL FOLLOW!

PLEASE NOTE: THE ABOVE IS A TENTATIVE LIST OF MEETINGS AND SUBJECT TO CHANGE. THE NEXT ISSUE ON NOVA NOTES WILL HAVE A FINAL LIST.

MINUTES OF THE JUNE MEETING

On June 17th, Graham Millar, a member of our Centre, gave a very interesting presentation on Babylonian Astronomy. The Babylonians, he stated, were the first to treat astronomy with mathematics (arithmetic). The development of arithmetic techniques allowed them to predict planetary positions with amazing accuracy. When reckoning the year, they used the spring equinox to start the Babylonian year.

Graham compared the Babylonian temple, the ziggurat, to the pyramids and the Druid's Stonehenge. These pointed to the rising sun of the summer solstice. The ziggurats were thus not only temples but also observatories. The observations were kept on cuneiform tablets, enabling the Babylonians to record the daily, monthly and annual cycles of the celestial motions - thus ephemerides. It is still amazing how archaeologists have been able to find out so much from the fragments of these ancient tablets about Babylonian astronomy.

Thank you Graham, for your informative presentation.

Kathy Oakley then showed a few slides on the recent General Assembly at Quebec.

Wilf Morley,
Secretary

NOTES FROM

THE LUNENBURG COUNTY ASTRONOMY CLUB:

Going to be in Bridgewater on a Saturday night this summer? If the answer is yes, then stop by the Desbrisay Museum for an;

"Observing Session in Bridgewater"

hosted by the Lunenburg County Astronomy Club. If you can, bring a scope or binoculars of your own!

Each Saturday night, that it is clear or almost clear, a session will be held. It will start in the evening at about the time that Venus will become visible to the naked eye. These observing sessions, which commenced on June 18, will run until Saturday, 20 August inclusive. If memory serves correct, we should encounter about two clear sessions out of the possible ten dates scheduled (if only we could have the weather of California!).

The Desbrisay Museum is located on Jubilee Road in/near the town park which is itself in the middle of a large residential section in the south end of town. More important than this are the accompanying dark skies (by town dweller standards) which afford reasonably good viewing of most celestial objects that one would be concerned with on an observation of this type. The only real problem with this site is the rather bright lights of the museum, which for security reasons, must be left on. Do not let these lights keep you away though, because of their position and aim they only interfere with a small portion of the south-east sky.

As an example of the viewing from this site; during our last observing session we focused on M57, the famous Ring Nebula in Lyra and found it to be an easy object to view in a Celestron C5.

Everyone who viewed this "interstellar smoke ring" had very little trouble in locating the oblong doughnut shape. Incidentally, this observation took place through a 12mm eye-piece while there was still a glow in the western sky.

Throughout the summer, apart from viewing the obvious celestial objects: mountains and craters on the moon, the wispy grey cloud belts of Jupiter, the beautiful rings of Saturn, famous doubles, and star clusters; we will also be zeroing in on particular constellations which are near the zenith.

So remember, if it is a clear Saturday night in Bridgewater this summer, drop by the Desbrisay Museum for a very enjoyable public observing session. There will be at least one C5 there and you are encouraged to bring an instrument of your own.

Good Observing to All

Darrin Parker

Observing Chairman, LCAC

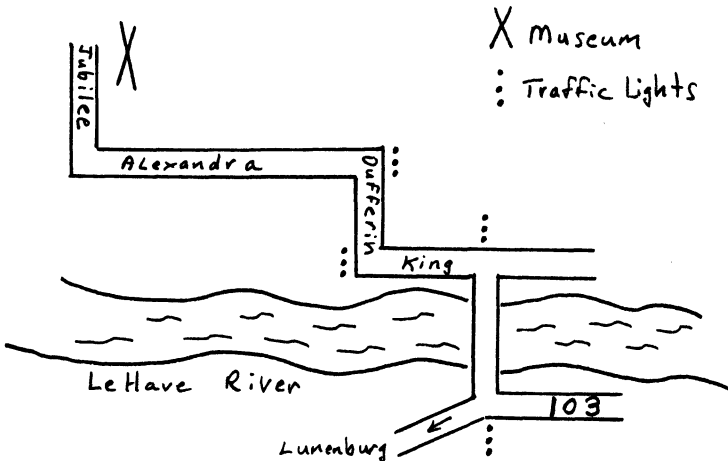

Directions to the Desbrisay Museum/Bridgewater

VOIDS AND SUPERCLUSTERS

For some years now astronomers have been studying the distribution of galaxies in an attempt to determine the size of the larger inhomogeneities in the universe. Robert Kirshner of the University of Michigan and his colleagues have contributed to this study by performing a survey of galaxy redshifts. Their survey covered three small areas of the sky in the general region of Boötes and Corona Borealis. Each survey area was 1.4 degrees square and was separated from the others by approximately 35 degrees.

A count of the number of galaxies within given redshift ranges in all three survey areas shows a large excess of galaxies on either redshift side (i.e., foreground and background) of an area containing almost no galaxies. The centres of the excesses correspond to distances of about 100 megaparsecs(MPC) and 210 MPC and the approximate borders of the redshift gap are 135 MPC and 180 MPC. Kirshner's group suggested that because this gap in the distribution appears in all three survey areas it also probably exists in the space between the survey areas. If this were so it would mean that the gap could occupy as much as one million cubic megaparsecs! Kirshner calls this gap, "the void".

Actually the use of the word void is somewhat misleading since it implies a total absence of matter. The void is best described as a decrease in the number of galaxies within a certain distance range. This decrease in number density is enhanced by the large number density increases on either side of it.

Neta Bahcall and Ray Soneira of Princeton University have shown that the locations of the

number density increases correspond to the locations of a number of superclusters. They claim that the number density decrease is due to the separation between the superclusters.

These findings help to establish the size of the larger inhomogeneities in the universe as well as suggest a possible spatial relationship between superclusters and voids.

Bill Allwright

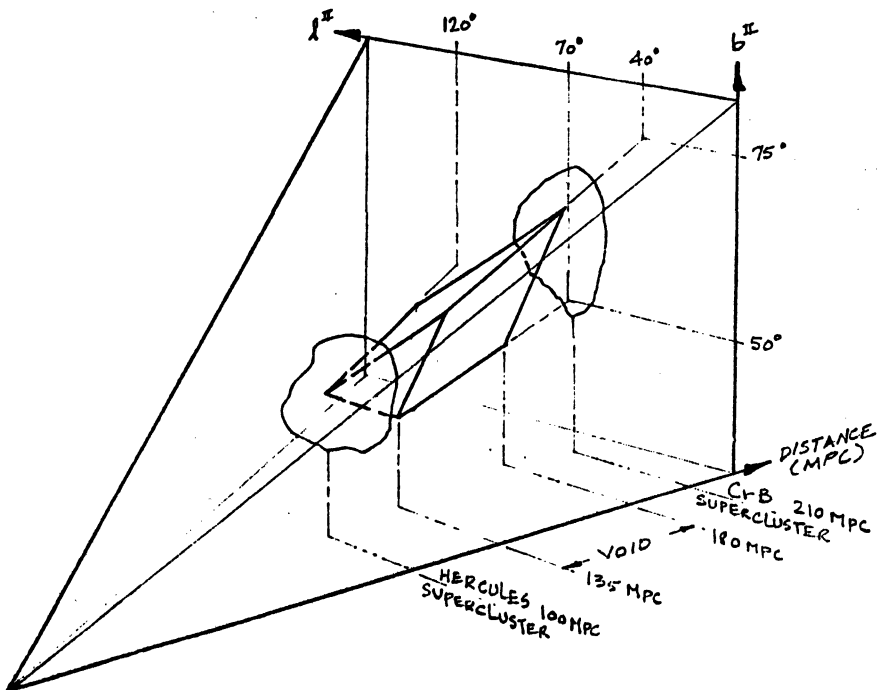

The above diagram gives a rough indication of the relative positions of the void and some of the surrounding superclusters.

COMETS

The name comet is probably derived from the Greek "aster kometes" meaning longhaired star. Anyone who has seen a comet or a picture of one would agree that most comets do look like "stars" with "long, wind-blown hair". For centuries comets have fascinated many people, struck terror in the hearts of others and have been considered harbingers of death, disaster, war, birth or good fortune. Today, however, the majority of people consider comets to be interesting objects to observe and study as they may hold clues to the original composition and formation process of the solar system. It is generally believed comets were formed at the same time and from the same cloud of interstellar matter as our solar system, and, therefore, are samplings of that original material.

About 10^{11} cometesimals exist in a spherical halo around our solar system. This reservoir, known as Oort's Cloud, lies between 2.0×10^4 a.u. and 1.5×10^5 a.u. from the sun, outside another reservoir which, according to J.G. Hills (1981),³ contains $\sim 10^{13}$ comets with semi-major axes between 10^3 and 2.0×10^4 a.u. Comets in these reservoirs are moving very slowly (~ 0.1 km/sec) and are only loosely bound to the sun so that their orbits are easily perturbed by passing stars and giant molecular clouds (Biermann 1978). The perturbed comets can be sent out into interstellar space or into the solar system on elliptical or parabolic paths. These encounters also serve to randomize the distribution of cometary orbits within the cloud (Whipple 1974). When a comet enters the solar system, the planets, especially Jupiter, may further alter its trajectory and expel the comet back out of the solar system or trap it in a short period elliptical orbit about the sun.

Cometary orbits are difficult to determine accurately since we observe only a fraction of the comet's complete orbit (when it approaches perihelion) and the gravitational perturbations of the planets as well as non-gravitational effects (the asymmetric evaporation of material from the nucleus) (Whipple 1951) will alter the orbit. However,

if one merely wants to calculate a general Keplerian orbit, one needs only to make a few good position measurements and determine the orbital parameters (see Tatum 1982a, Tatum 1982b for descriptions of these procedures). The six parameters which describe a comet's orbit are: 1) q , the perihelion distance in a.u., 2) e , the orbital eccentricity, 3) T , the date of perihelion passage, 4) i , the inclination of the orbital plane to the ecliptic plane, 5) Ω , the ecliptic longitude of the ascending node (measured east from the vernal equinox), 6) ω , the angular distance of perihelion from the ascending node (called the argument of perihelion) (Brandt 1981). Usually, at least three observations of the comet are required to determine these orbital parameters.

The most generally accepted model for the structure of the cometary nucleus is the "dirty snowball" model presented by Fred Whipple in a series of papers beginning in 1950. The "dirty snowball" is an icy conglomerate of water, ammonia, methane, carbon dioxide and carbon monoxide ices with dust particles embedded throughout. The radius of the nucleus varies between a few hundred meters and 10 km. masses range from 100 million to 10 trillion metric tons. The nucleus is the source of the dust and gases which form the comet's tails. When the comet is far from the sun (beyond the orbit of Saturn) it is relatively inactive. However, when it passes within 3 or 4 a.u. of the sun, the outer layers of ice heat up and then begin to sublimate. As these outer layers sublimate dust particles are freed from the ices and together with the gases, surround the nucleus to form the coma. This coma can extend to 10^5 to 10^6 km in radius and typically reach a maximum when the comet is 1.5 to 2.0 a.u. from the sun (Whipple 1951). The coma gases flow away from the nucleus at approximately 0.5 km/sec, sometimes forming rings or halos which are visible around the sunward side of the nucleus.

Many comets are also surrounded by a giant hydrogen/hydroxyl cloud which extends out to 10^7 km in diameter (larger than the sun!). These H/OH clouds are most conspicuous in Lyman α (λ 1216) radiation. Their presence

was predicted by L. Biermann in 1968; they were first observed in 1970 around Comet Tago-Sato-Kosaka (1969 IX) with the OAO-2 (Second Orbiting Astrophysical Observatory) and around Comets Enke and Bennet (1970 II). The presence of these clouds seems to indicate that H_2O is a principal constituent of the cometary nucleus since H and OH can originate from the dissociation of water molecules (Brandt 1981).

The majority of comets develop two tails, a plasma or ion tail (Type I) and a dust tail (Type II). Dust tails are formed when particles in the coma are swept away from the coma by solar radiation pressure. The dust tail is curved, 10^6 to 10^7 km long and appears yellow or white in color due to the reflection of sunlight by the dust particles. Occasionally, a comet will display more than one dust tail. Each tail will have a different radius of curvature and will be composed of different sized particles. Several comets, the best known of which is Comet Arend-Roland (1957 III), display an antitail, a spike or fan-shaped tail which appears to point towards the sun. Antitails are formed by relatively large (>0.1 mm) particles which are swept away from the coma and tail and disperse along the orbital path in a fan-shaped sheet. This material appears projected as a sunward-pointing spike when the Earth passes through the plane of the comet's orbit and as a fan-tail just before and after this point. Since the particles in this cloud are relatively large they experience a small or negligible repulsive force and are, therefore, not blown out of the solar system. They probably contribute to the zodiacal light and the meteor streams seen from the Earth.

Plasma tails are formed when ionized particles from the coma are coupled to and swept away by the magnetic field lines in the solar wind. This plasma tail is straight, 10^6 to 10^8 km long and appears blue due to the emission of CO^+ and other ions. These tails do not usually appear until the comet is 1.5 to 2.0 a.u. from the sun (when the ices begin to sublimate), but they have been seen on comets which are much more distant, e.g. Comet Humason (1961e) at 5 a.u. and sometimes do not appear

at all or are negligible, e.g. Comets Baade (1945h) and Haro-Chavira (1954k) showed well developed dust tails at large distances from the sun but have no plasma tails. Knots and kinks often appear in these tails and move away from the nucleus with speeds varying from 10 km/sec near the nucleus to 250 km/sec farther away. These knots of material will, at times, disconnect and drift away from the rest of the comet. The comet may then "grow" a new plasma tail (Biermann 1958).

About 10 comets are observed each year, five of them will be new comets entering our solar system for the first time, while the others are periodic comets making return trips. They appear in our skies for a few months, often as awe-inspiring naked-eye objects, make their passage about the sun and then fade from view as they continue their journey into the darkness of space. Some will return again in 10 years or one million years, but the others are just passing by on their way out into interstellar space.

References

- Biermann, L.F. and Lüst, Rhea. 1958. 'Tails of Comets', Scientific Am. 199,44.
- Biermann, L.F. 1978. 'Astronomical Papers Dedicated to Bengt Strömgren', Eds. A. Reiz and T. Anderson. Copenhagen Observatory, Copenhagen. p.327.
- Brandt, J.C. and Chapman, R.D. 1981. Introduction to Comets, Cambridge University Press, New York.
- Hills, J.G. 1981. Astron. J. 67, 1730.
- Tatum, J.B. 1982a. J. Roy. Astron. Soc. Canada. 76,97.
- 1982b. J. Roy. Astron. Soc. Canada. 76,157.
- Whipple, F.L. 1951. 'Comets', Scientific Am. 185,22.
- Whipple, F.L. 1974. 'Nature of Comets', Scientific Am. 230,48.
- van den Bergh, Sidney. 1982. J. Roy. Astron. Soc. Canada. 76,303.

ANCIENT MEASUREMENTSTHE SIZE OF THE EARTH

The size of the earth was first determined by Eratosthenes a Greek scientific writer, poet and astronomer who lived in Alexandria, Egypt about 250 B.C. Eratosthenes noticed that in the town of Syene (now Aswan), which is south of Alexandria, on the longest day of the year when the sun was at the meridian, sunlight fell straight down a well. In Alexandria, he noticed the shadow at the base of a tall pillar did not disappear completely when the sun was at the meridian. He measured the length of the shadow when it was at its shortest, and the height of the pillar. With these two measurements he determined the difference in the angle between the two points. Eratosthenes considered the sun to be infinitely far from the earth so that light rays falling on Syene and Alexandria would be parallel. The distance from Alexandria to Syene is 5000 stadia (one stadium is about 517 feet), or about 500 miles. There are 360° in a circle, and the angular distance between Syene and Alexandria is $7\frac{1}{4}^\circ$. The ratio of 360 to $7\frac{1}{4}$ is about 50 to 1. Hence the distance around the earth is 50×5000 stadia, or about 24,500 miles, which is a close approximation of the actual distance. Eratosthenes also worked out a calendar that included leap years, and tried to fix dates of important events. Afflicted by blindness in old age, he is said to have committed suicide by voluntary starvation.

Peter Steffin

FASTER THAN THE SPEED OF LIGHT?

There was a young girl named Miss Bright
 Whose speed was far faster than light
 She departed one day/In a relative way
 And came back the previous night.

Reginald Buller

FOCUSING ON CONSTELLATIONS

METEOR SHOWERS

This summer's camping weekend is planned to coincide as closely as possible with the Perseid meteor shower, August 12th. August evenings are usually warm and it is enjoyable to lie out under clear skies to count meteors. Summer is not the only time for meteor displays, and the Observer's Handbook lists 10 major annual meteor showers as well as 13 minor ones.

Rather than featuring any one constellation in this Nova Notes issue, the star charts show five of the major meteor shower radiant points for summer and fall scheduled meteor showers. Can you identify the showers? See the Observer's Handbook for a good writeup about these five, and several other meteor showers. Good luck observing at the camping weekend, both the Perseids, and the general sky!

J. Norman Scrimger.

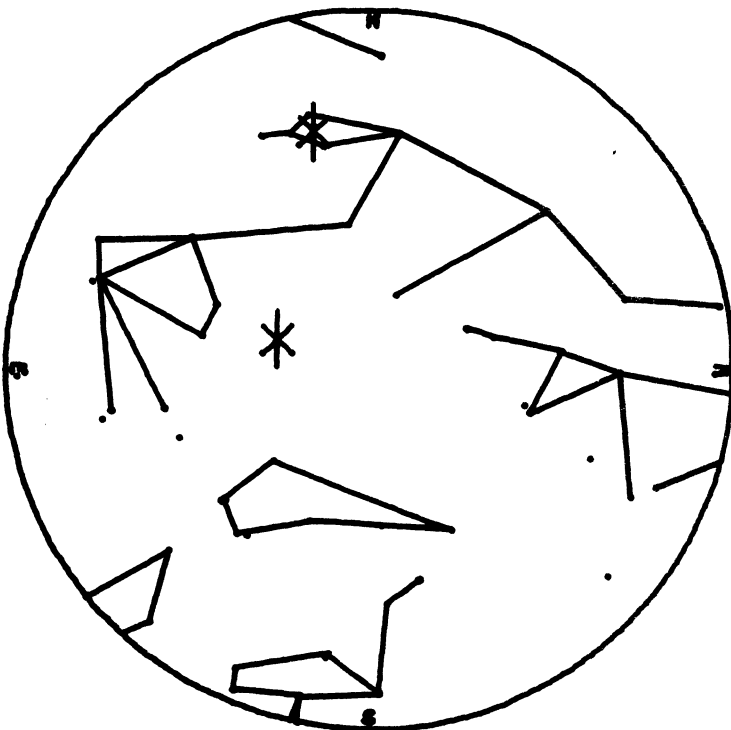

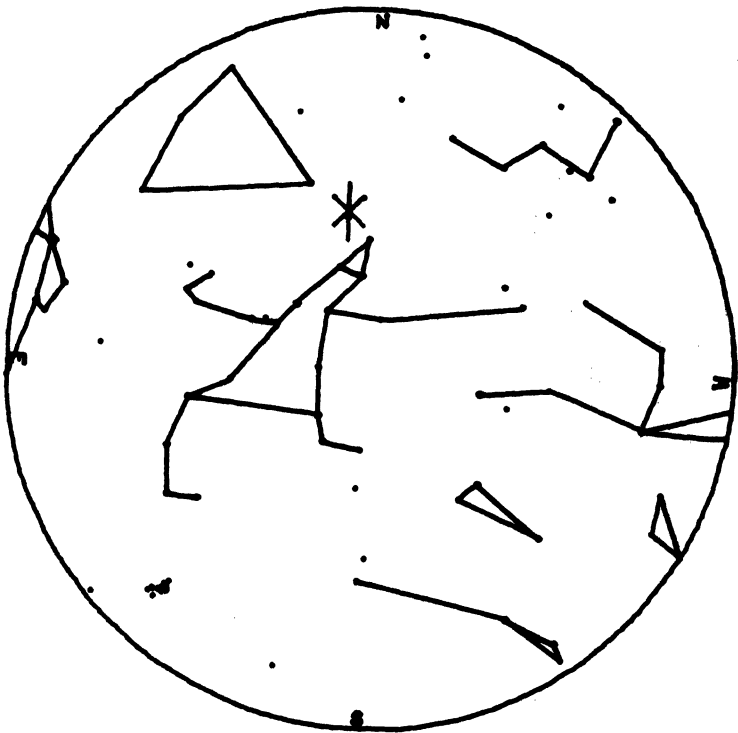
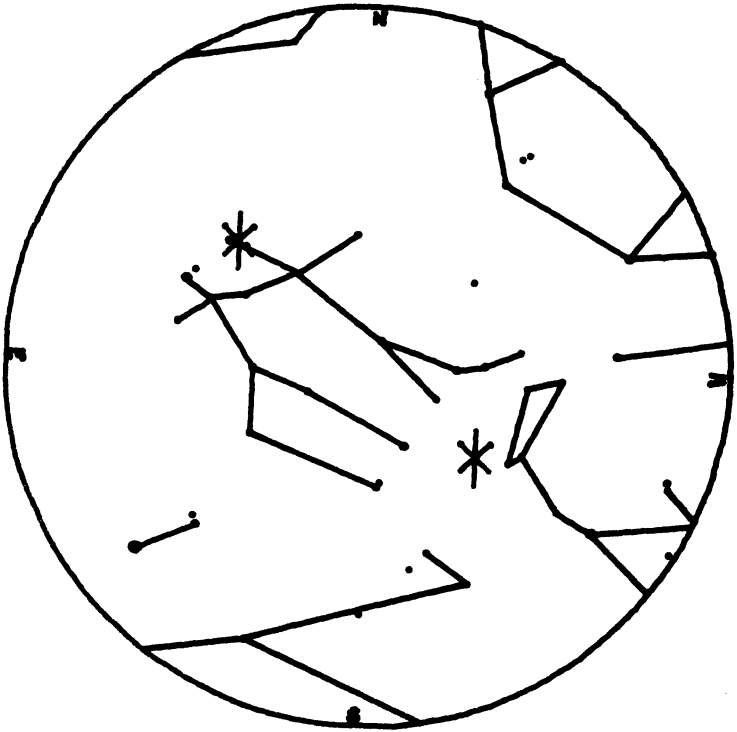

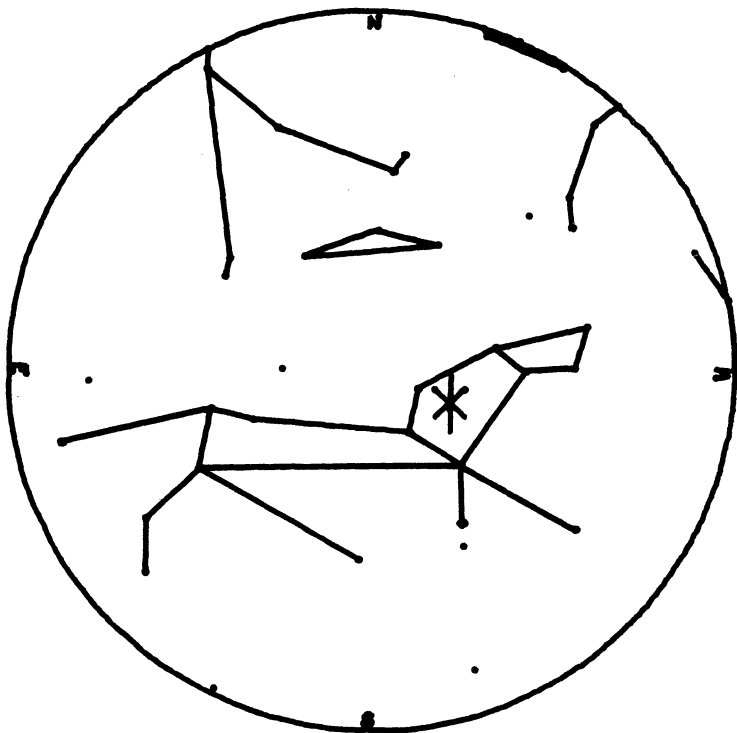
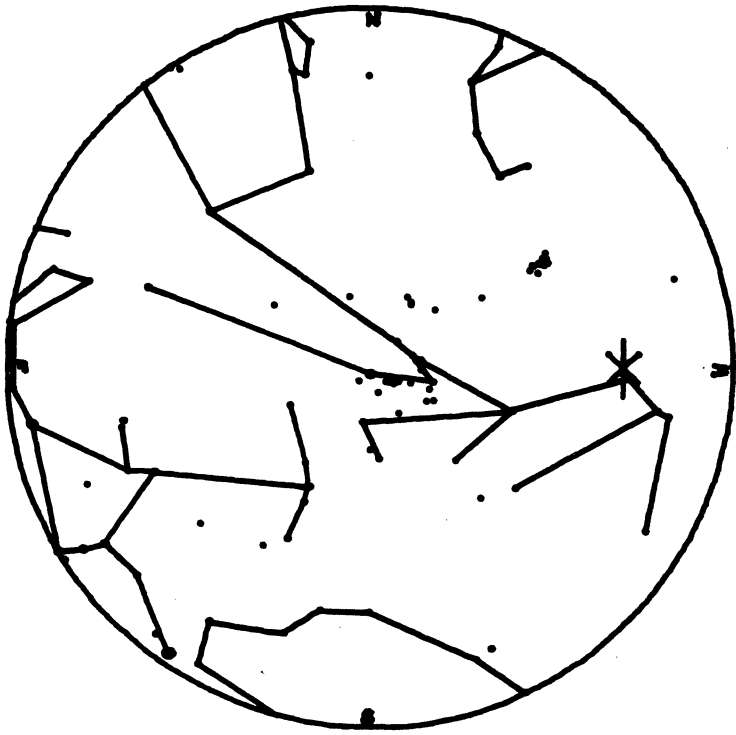

Seasat Results

Images recently produced from data collected by the Seasat oceanographic satellite flown by NASA in 1978 show major geologic features on the ocean floor. The images, made by measuring the topography of the ocean surface with the satellite's altimeter, create a global image comprised of more than 50 million physical measurements, including ten corrections for atmospheric and other interferences. The measurements were produced by the same data, but each was processed differently to emphasize a unique set of features.

The images supply new, detailed bathymetric (water depth) and geologic information for wide areas of the world's seas, especially in the southern oceans. Existing bathymetric charts show the Louisville Ridge as a discontinuous chain of mountains running southeast of the Tonga-Kermadec Trench. The Seasat image of this region clearly shows a nearly continuous chain of features.

Seasat collected 70 days of oceanographic data over a 100-day period. The radar altimeter measured the distance from the spacecraft to the ocean surface. By calculating the satellite's position, and correcting for passage of the radar beam through the atmosphere, the height of the ocean surface relative to a reference ellipsoid was determined.

The resulting maps, which show the ocean surface at one-half degree resolution, were created through computer processing of the Seasat altimeter data. They are designed to emphasize features on the ocean floor ranging in size from 50 to 500 kilometers.

Mapping the sea floor by measuring the sea surface topography is possible because of the relationship between gravity, the sea floor, and the ocean. Gravity over the Earth is not constant; it varies depending on the local thickness, density, age, and geology of the crust. The ocean conforms to variations in this uneven gravity field because it is a fluid. Sea surface topography dominantly conforms to the sea floor topography. A mountainous formation on the sea floor, for example, causes a peak on the ocean surface detectable by a satellite altimeter.

*From NASA
Headquarters*

WILLIAM HERSCHEL SOCIETY AND HERSCHEL HOUSE

In May, Diane and I visited Bath, England primarily with the intent of visiting Herschel House. The last time we had been in Bath, the House had not yet been restored and opened as a Museum, so we were hoping to see what progress had been made since its official opening in March 1891. Unfortunately, we were to be disappointed again as we arrived on a day when the House was not open. The Museum is cared for by volunteer stewards and because the operating society, The William Herschel Society, is small and still very young, the House is open only on Wednesday and Saturday afternoons although groups and Society members can be accomodated at other times by prior arrangement.

The Society has been functioning for 5 or 6 years and currently has some 180 members in the UK and 40+ overseas. The President is Dr. Patrick Moore and Caroline Herschel, great, great grand-daughter of William, is Patron of the Society. The House is owned by Dr. Leslie and Mrs. Elizabeth Hilliard who have done much of the restoration and who provide the House as a Museum to the great astronomer. The Society's purpose is primarily the operation of the Herschel House Museum but they now also sponser an annual lecture in March to commorate Herschel's discovery of Uranus at his 19 New King St. home. IBM has helped with the expenses of the lecture series and the texts are reprinted in the Journal of the British Astronomical Association. Next year's lecture is to be held 9 March 1984 with the Astronomer Royal, Prof. Graham Smith speaking on "Telescopes, Old and New". The lectures are held in the Pump Room of the Baths.

Herschel House was official opened 13 March 1981 on the 200th anniversary of Herschel's discovery of Uranus in the garden of the House. Leading up to and since the opening, the interior and exterior of the House have been completely refurbished, refurnished and the garden restored with plants, shrubs and herbs. Furniture of Herschel's period has been obtained from the Victoria and Albert Museum in London and from the Museum of Bristol for the main and upper floors. The

Nation Maritime Museum of Greenwich has also prepared exhibits for the House which cover the life of Herschel, his activities as an astronomer and as a musician. Other exhibits relating to Herschel have been donated by Museums and individuals from Britain, the US and even as far away as South Africa. The latter connection is not too surprising since William's son, John, observed from the Cape Observatory for several years using his father's best and most famous telescope--the 20 foot. The exhibits include examples of Herschel's mirrors, his laythe which is set up in the workshop in the basement, a model of the 40 foot telescope, portraits, and musical instruments. In the Music Room, visitors can hear the strains of four sonatas composed by Herschel himself. Since the Museum opened an average of 1200 visitors per year have found their way to 19 New King St. and they are hoping for larger numbers with increased publicity. However, such a limited schedule limits the numbers which might otherwise like to see Herschel House.

If you're interested in supporting the continued existence of the Herschel House Museum, you can become a member by sending £2.50 to the Treasurer, Wm. Herschel Society, 2 Lambridge, Bath England, BA1 6BJ. The Museum's maintenance and operation relies heavily on donations, membership fees and sales of publications so they will be pleased to hear from you. The publications include:

P. Moore, "Wm Herschel, Astronomer and Musician of 19 New King St., Bath" (£1.50 + 20p post)

Wm Herschel, "Account of a Comet (Uranus)" reprint from Philosophical Transactions (£1. + 20p)

Francois Arago, "William Herschel" reprint from his Famous Scientists book (£1. + 20p)

First day cover stamp (13 March 1981) commemorating the 200th Anniversary of the discover of Uranus (95p).

R. C. Brooks

40 CM REALUMINIZED

The 40 cm mirror of the telescope in the Burke-Gaffney Observatory recently required realuminization as any mirror will occasionally. It hadn't been done for 4 years, but with occasional washings, it had remained in reasonable shape. Despite small spots and a general haziness over the mirror, it was still reflecting about 75% of the incident light, so it wasn't necessary to go to the effort of aluminizing til now. For us, the dangers associated with shipping the mirror forces us to leave it longer than we would if we had the facilities to do an aluminizing job ourselves. We have taken the mirror for the last 3 coats to the Univ. of Toronto's facilities at Richmond Hill (David Dunlap Observatory).

The U of T has two aluminization chambers one will hold mirrors up to 60cm and the larger will hold their 1.85m mirror. The first step in the process is of course to clean the surface. Running water is flushed over the surface to remove lint. An acid, nitric I believe, is poured over the old aluminum coat to strip it off. With soft cotton balls or Kim-wipes, the surface is gently cleaned again with running water, or if there are very stubborn spots or oil on the surface, with acetone. Once thoroughly cleaned, distilled water is flushed over the mirror and finally methanol is used to ensure the mirror dries rapidly and without drying marks.

The mirror is then placed in the vacuum chamber along with the secondary mirror which is prepared in the same fashion. They are placed in a verticle position which is preferable since mirrors in the horizontal orientation can have spatters of aluminum fall on the reflecting surface. Because of its size, the 1.85m is aluminized in the horizontal position. The small chamber has 8 coils, the larger 36. Each of these has 3 small 'charges' of aluminum placed on it. Aluminum wire which is 99.9% pure is bent in a loop and hung over the coils prior to pumping down. The vacuum chamber is equipped with a fore-pump which will eacuate it to 10^{-3} Torr. A diffusion pump is then turned on which will take it down to 5×10^{-5} Torr. The pumping time is about $2\frac{1}{2}$ to 3 hours for the small chamber and several hours for the larger chamber.

At this point the high current source is hooked up. This supplies 100 amps at 8 volts (800 watts of power) to each coil in turn. This is sufficient to cause the small pieces of aluminum to melt and flow along the coils in the same fashion as solder melts on a wire. This takes about 10 seconds and if you watch the meter on the current source, you can see a blip as each of the three charges melts. The current then causes the melted aluminum to evaporate in 15-20 seconds and this then coats everything in the chamber with a thin coat of aluminum. Immediately after firing, the pressure in the chamber rises to 7 or 8×10^{-5} Torr but 5 minutes of pumping draws it back down. It was interesting to see that the vacuum actually improved to about 2×10^{-5} after firing each coil. Apparently the aluminum vapour acts as a 'getter' attracting the remaining air molecules.

A newly coated mirror, in the eyes of an astronomer at least, is a thing of beauty. A fresh coat reflects about 92% of the incident light in visible wavelengths. However, a new coating is very soft and can be easily damaged. After a month or so, sufficient oxidation of the surface layer will have taken place to harden the aluminum. After this, one can wash the surface, using great care of course, with little danger of scratching the coating. Some observatories use overcoatings to improve the reflectance or to protect the coat from the elements, but our limited experience with such coats has not been very good, hence we do not go to the additional expense or trouble to overcoat the aluminum.

Once safely back in Halifax, the mirror was replaced in the telescope ready for another four years of observing. We expect the telescope drives will be refurbished this summer as well, so this fall should see some successful observing. You should be reminded that RASC members have a standing invitation to use the telescope during and after our Saturday evening tours.

R.C. Brooks

NEW MEMBER:

The Halifax Centre welcomes Walter Kauzmann as a new member. Mr. Kauzmann has transferred from an Unattached (US) member and now resides in Dingwall.

THE HALIFAX CENTRE LIBRARY

A LIST OF BOOKS, BY SUBJECT, AVAILABLE

Astronautics	Mathematics
Astronomy-Descriptive	Meteors
-General	Moon
-Practical	Observing Techniques
Atlases-Constellations	Photography
Biography-Astronomers	Physics-General
-Scientists	Planetaria
Calendars	Planets
Catalogues	Radio Astronomy
Celestial Mechanics	Satellites
Cosmology-Universe	Science-General
Dictionaries,Encyclopedias	-Philosophy
Earth Sciences	Solar System
Galaxies	Stars
History of Astronomy	Sun
History of Science	Telescopes
Lectures-Astronomy	Weather
Life Elsewhere	

A Few Reminders:

-Books can be signed out for an initial period of two months, after which they must be renewed.

-The Library is open before, during and after each meeting of the R.A.S.C. For those who live great distances from Halifax and are unable to get to the meetings, we will, upon request, put one or two books in the mail, we will pay the initial postage costs, however, the borrower must pay the return postage.

-Our Address is:

L. Burgoyne/J.S. Wells
 Department of Astronomy
 Saint Mary's University
 Halifax, N.S., B3H 3C3

-If you have any books (or money) you would like to donate to the library, or there is a book we don't have that you would like to see in the library, please do not hesitate to let us know.

July/August	NOVA NOTES	Vol 14 No 4
1983 Halifax Centre Executive		67
Notices		68
Notice of Meeting		69
Minutes of June Meeting	Wilfred Morley	70
LCAC Notes	Darrin Parker	71
Voids & Superclusters	Bill Allwright	73
Comets	J.S. Wells	75
Ancient Measurements	Peter Steffin	79
Focusing on Constellations	Norman Scrimger	80
Seasat Results	NASA	83
William Herschel Society & House	R.C. Brooks	84
40 CM Realuminized	R.C. Brooks	86
Halifax Centre Library	L. Burgoyne & J.S. Wells	88

NOVA NOTES ARE PUBLISHED BI-MONTHLY
 BY THE HALIFAX CENTRE R.A.S.C. IN
 JAN, MAR, MAY, JULY, SEP, AND NOV.
 ARTICLES FOR THE NEXT ISSUE MUST
 REACH THE EDITOR BY 19th. AUG, 1983.
 ARTICLES ON ANY ASPECT OF ASTRONOMY
 WILL BE CONSIDERED FOR PUBLICATION.
 EDITOR: Peter Steffin, 8 Auburn Dr.,
 DARTMOUTH, N.S. B2W 3S6 / 434-4541

NOVA NOTES IS PRINTED BY N.S. MUSEUM